

A Brief Profile

ProModel Provides Simulation-Based Decision Support Solutions that allow organizations to understand system performance in a low-risk environment, enabling Automotive Manufacturers to:

- Visualize Operations in virtual environment
- Analyze the performance of systems based on a multiple configurations
- Optimize and Maximize performance prior to implementation

Our Customers

Vehicle Manufacturers

- Toyota
- Subaru
- GM
- Nissan
- Honda
- Volkswagen
- Navistar Trucks (International)
- Daimler
- Harley Davidson
- Defense Contractor Vehicles
 - General Dynamics
 - Textron
 - BAE

Tier 1 Suppliers

- Denso
- Benteler
- IAC
- Mahle
- Nemak
- Yazaki
- TRW
- Lear
- Brose

Customer Project - Materials / Inventory Management Analysis

Situation:

Phase 1: Model production capabilities to ensure plant was capable of increased production levels

Phase 2: Analysis of material handling, and replenishment strategies to Reduce Plant Inventory levels of sub-assemblies while maintaining production levels

- Focus was to look at Line-side and market place reorder points and quantities while taking into account variable lead times from their supplier to minimize the WIP held onsite
- The material handling types and quantities were analyzed to right-size the labor and equipment for the specified frequency of deliveries

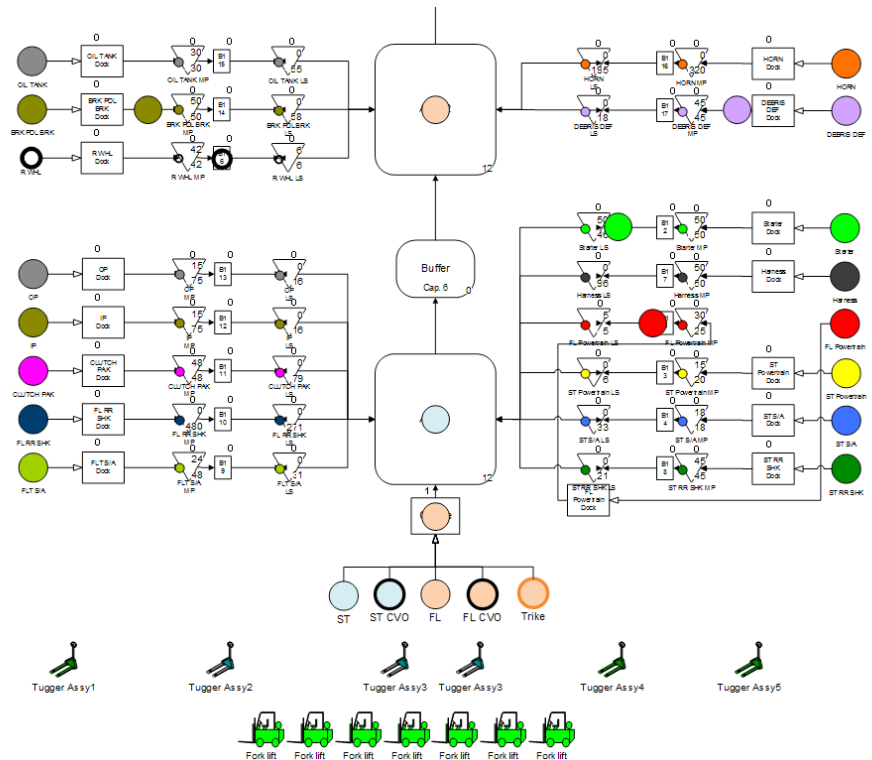

Analysis Showed:

Minimum level of inventory the client could keep Lineside and in their Marketplace represented a 50% reduction in inventory holding costs

Space needed for subassemblies lineside was significantly reduced making room for future growth

Current planned MHE level could not support the level of deliveries; client avoided potential issues by identifying in the model the specific number of resources needed to support the replenishment strategies.

Core Competencies:

Products

ProModel Optimization Suite
Process Simulator
Enterprise Portfolio Simulator

Services

U.S. Based Customer Support
Training
Consulting – Model Building Systems

Achievements

Microsoft Gold Partner
Microsoft Partner of the Year

Areas of Focus:

Manufacturing

- Production Line Design
 - Test Layout Concepts
 - Identify Bottlenecks
 - Maximize Throughput
- Optimize Operations
 - Mixed Model Planning
 - Labor Planning
 - Resource Utilization
- New Product Launch
- Continuous Process Improvement Support

Logistics

- In-Plant Logistics Design
 - Material Handling Route Planning
 - AGV System Design
- Warehouse Design and Planning
 - Labor Planning
 - Slotting Analysis
 - Test Pick / Putaway Strategies
- Supply Chain “Optimization”

Customer Project - Capacity Analysis for a Tier 1 Supplier of Suspension Production Lines

Situation:

Plant-wide capacity planning model was needed to ensure that proposed line changes would meet throughput requirements. Model was built to measure throughput, cycle times, inventory levels and labor and equipment needs of the system.

The material flow of major components was modeled between the warehouse and line side storage to determine the number of workers and level of inventory needed to support production goals. The material flow process was modeled and included line side inventory buffers, product container sizes, material handling equipment, and packaging removal from line side storage area.

- Utilized 'to-scale' AutoCAD layout to physically depict facility and spatial constraints
- Analysis was able to take into account travel distances and routes taken by fork trucks, AGVs, and Tuggers

Analysis Showed:

- Determined quantities and frequencies of material replenishments
- Determined quantities of AGV's and Fork trucks for material delivery
- Determined capability of overall production to meet throughput estimates

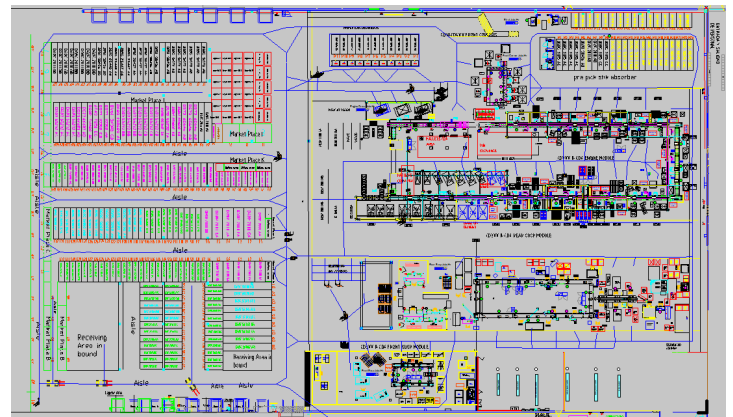

AMR-21/06

www.promodel.com

888.900.3090 | saleshelp@promodel.com

ProModel[®]
Better Decisions—Faster